

2 FOUNDATION

2.1 Foundation design

The factors affecting the foundation design are:

- Height of the mast
- Wind exposed area of the instruments (including the obstruction light and the lightning conductor, if fitted)
- Wind load (including jet blast loads caused by the aircraft engines in the proximity of the threshold)
- Soil quality

The following tables describe some typical examples of mast foundations. The calculations have been made for lattice masts carrying instruments with total wind exposed area of 0,7 square metre (700 000 mm²). The maximum wind speed used in the calculations is 40 m/s. Dimensioning of the foundations has been done according to DIN V 4017-100.

Two types of foundations have been calculated, slab foundation and drum foundation.

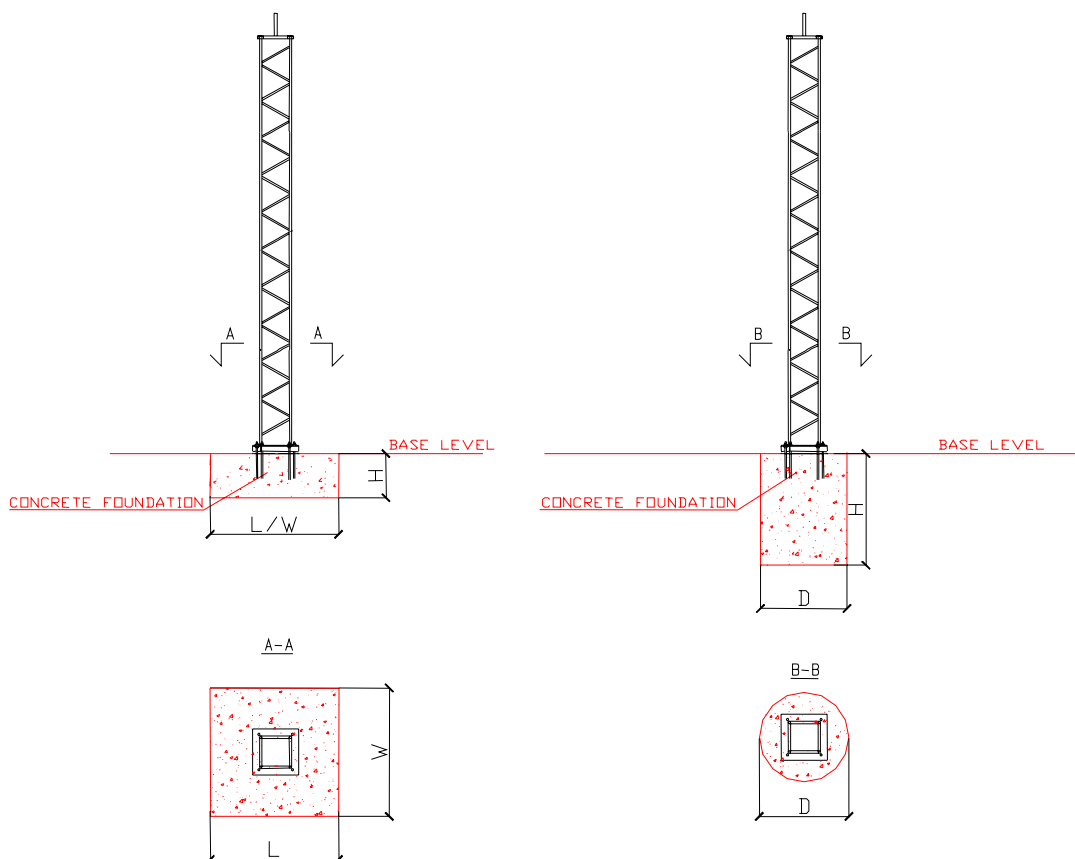

Illustration 2: Slab foundation and drum foundation

Slab foundation		SOIL TYPE 1			SOIL TYPE 2			SOIL TYPE 3		
Mast height	Type	L=W	H	Mass	L=W	H	Mass	L	H	Mass
Meters	-	mm	mm	kg	mm	mm	kg	mm	mm	kg
H = 4	Lattice	1200	400	1400	1100	400	1200	1300	500	2100
H = 7	Lattice	1400	600	2900	1300	600	2500	1600	700	4400
H = 10	Lattice	1700	700	5000	1600	700	4400	1900	800	7100

Table 2: Dimensioning of the concrete slab foundation for mast heights up to 10 m.

Drum foundation		SOIL TYPE 1			SOIL TYPE 2			SOIL TYPE 3		
Mast height	Type	D	H	Mass	D	H	Mass	D	H	Mass
Meters	-	mm	mm	kg	mm	mm	kg	mm	mm	kg
H = 4	Lattice	1200	1100	3000	1200	900	2500			
H = 7	Lattice	1200	1500	4150	1200	1200	3350			
H = 10	Lattice	1200	1900	5260	1200	1500	4200			

Table 3: Dimensioning of the concrete drum foundation for mast heights up to 10 m.

Soil type 1: Sand, sandy soil
 angle of friction $\delta = 25^\circ$
 weight by volume $\gamma = 17 \text{ kN/m}^3$
 cohesion $c = 0 \text{ kN/m}^2$

Soil type 2: Compacted coarse sand and moraine
 angle of friction $\delta = 40^\circ$
 weight by volume $\gamma = 21 \text{ kN/m}^3$
 cohesion $c = 0 \text{ kN/m}^2$

Soil type 3: Hard clay (drum foundation should not be used!)
 angle of friction $\delta = 0^\circ$
 weight by volume $\gamma = 19 \text{ kN/m}^3$
 cohesion $c = 20 \text{ kN/m}^2$

Concrete: > K30

i

- In a groundwater area the foundation shall be deeper.
- In a soil frost area, the foundation shall reach below the soil frost penetration depth.



- All design values mentioned in this instruction are purely indicative. Exel Oyj shall not take responsibility for their applicability to the area in question.
- It is highly recommended to always consult a local civil engineer about the dimensioning of the foundation.
- Exel Oyj will provide the necessary load calculations (shear force and bending moment), when requested.

2.2 Preparation of foundation

Hinged base plate

Part of foundation bolt remaining visible	100 ±2mm
Allowed deviation of the position of the jig/base frame from the horizontal level.	± 0,3° =5,2mm/1000mm
Correct position of the base frame	Even side up

Table 4: Essential information necessary for preparation of foundation.



- Hot dip galvanised foundation bolts shall in no case be welded to the steel reinforcement of the foundation. Fasten the foundation bolts with wire.
- Protect the thread of the foundation bolts during the casting for example with tape.

i

- Plywood jigs (option) are available for locating of the foundation bolts in the concrete when casting the foundation.
- The position of foundation bolts is the same for both 400 mm and 500 mm module masts.
- The same hinged base plate can be used for both 400 mm and 500 mm masts.
- See appendices: "Assembly drawings".
- See appendices: "Foundation parts".

2.2.1 Equipment needed for preparation of foundation

Measure	Instrument	Size
-	Foundation bolt, 4 pcs 641861	M24-430(1160)
Fastening of foundation bolts to the jig	Nut, 8 pcs	M 24
-:-	Washers, 8 pcs	Ø26
-:-	Wrench	S=36mm
Positioning of foundation bolts (alternative 1)	Casting jig 641794C 1 pc	For 400 or 500 mm mast
Positioning of foundation bolts (alternative 2)	1 Base frame + locating bushes 641878, 4 pcs	For 400 or 500 mm mast
Protection of screw thread	Masking tape	-
Fastening of screws to steel reinforcement	Wire	-
Casting of foundation	Normal casting accessories (moulds and steel re-inf.)	-
Verification of level of the jig	Water level	-

Table 5: Equipment needed for preparation of foundation.

2.2.2 Work instruction for casting of foundation

If a locating jig is not available (option), the base frame can be used as a jig. Fit the base frame with locating bushes. They will centre the foundation bolts to the holes in the base frame and make sure that the bolts will be positioned accurately at their correct places in the concrete (see the illustration on the following page).

- Make a cast mould with its steel reinforcements in accordance with the design of a local civil engineer.
- Place the cable duct tubes in foundation prior to casting. Recommended duct tube IR 65. The cable duct is drawn under the ground through the foundation up to and as close as possible to either inside corner of the base plate that is facing the felling direction of the mast.
- Fasten the foundation bolts to the cast jig (or with the locating bushes to the base frame). If you use the base frame as a jig, make sure that you fasten and install the bolts correctly in accordance with the illustration on the following page, the flat surface up.
- Protect the threads in the anchor bolts by using for example tape.
- Place the casting jig (or the base frame) with its bolts at its' position. Fasten the bolts to the steel reinforcement with wire if necessary. The foundation bolts shall remain for the length of 100 mm above the concrete surface.
- Cast concrete in the foundation mould.
- Make sure that the cast jig (or base frame) is in a horizontal position. Correct the position before the concrete hardens.
- When the concrete is hard, remove the cast jig (or base frame).

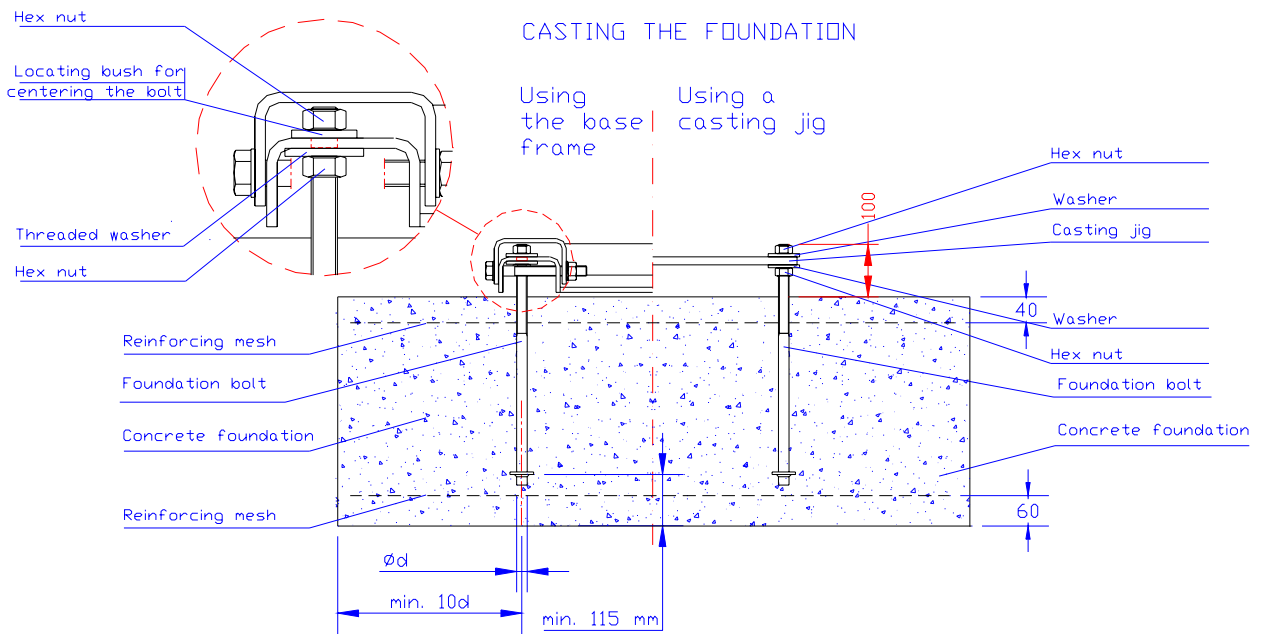

CASTING JIG

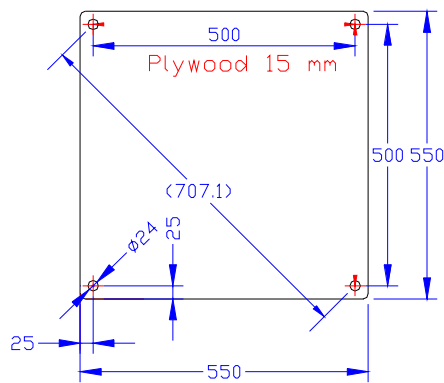

FOUNDATION BOLTS

HPM24/L KZN, L=430

HPM24/P KZN, L=900

Illustration 3: Principal draft of foundation, casting jig and foundation bolts of the mast.